



FR321 / 331

HOT AIR SHRINK TUNNEL

NARROW-BODY / WIDE-BODY WITH THREE HEATING ZONES



PRESENTATION

The narrow-body FR321 and wide-body FR331 shrink tunnel with three heating zones is suited to all types of barrier and non-barrier shrink films.

Used together with the new control system on the ES101 packager, the temperature settings in the two heating zones and the conveyor speed are controlled remotely.

Memorised ES101 product recipe settings result in significant time savings when switching between production runs.

The large number of available options allow the standard model to be adapted to the specific characteristics of your production run.

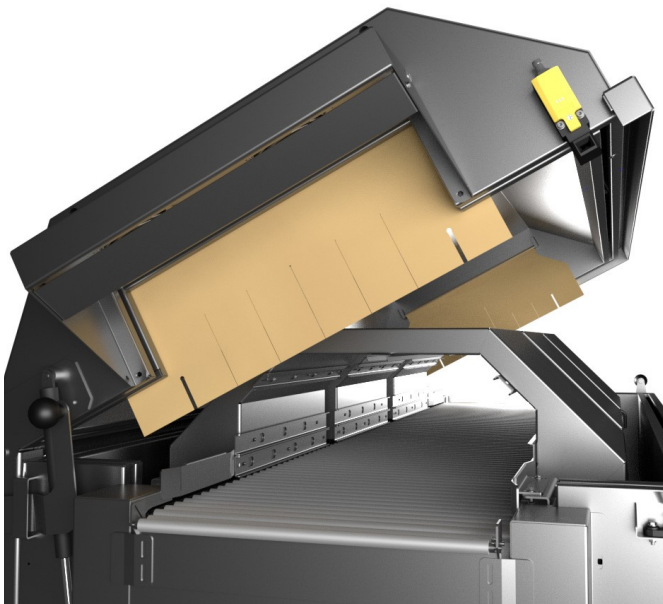

CONVEYOR

Composed of silicone coated rotating rollers

Ensures uniform heat distribution on the product and therefore an optimal retraction

Adjustable speed via potentiometer or by the horizontal wrapper upstream

Configuration available in left-to-right or right-to-left



SHRINK ZONE

Many air flow adjustments to optimize product presentation

Three heating stations with independent settings

Compatible with barrier & non-barrier shrink film

Suitable for different sizes and shapes of products

Several types of vaults :

- Type «T» vaults especially suitable for products in trays
- Type «F» vaults (see opposite) for varied heights of products such as cheese in portions or multipacks



EASE OF USE

Simple and accessible control panel

PID temperature controllers allow a clear visualization and precise temperature control

Temperatures can be manually set on controllers or directly from ES101 wrapper touch screen



CONSTRUCTION

Two pairs of fans placed at the entrance and exit of the tunnel form an air curtain preventing the hot air to diffuse into the production environment

Robust, high-quality frame, with heat insulation, stainless steel throughout

Adjustable frame height to provide the correct conveyor operating height

Simple and robust design to minimize maintenance and reduce costs

EXAMPLES OF PACKED PRODUCTS



STANDARD EQUIPMENT

Set of vaults according to need:

- Type «F» vaults (see opposite) for varied heights of products such as cheese in portions or multipacks
- Type «T» vaults especially suitable for products in trays

OPTIONS

- Front opening
- Speed increase kit
- Motorized kit IN / OUT kit, recommended for products less than 80 mm length
- Automatic conveyor chain lubrication
- System to communicate with JNJ packager
- Motorised ventilation
- Conveyor chain lock
- Additional set of vault of type F or T heating station

TECHNICAL INFORMATION

.The values shown below are indicative only and can be adapted to the customers specific needs.

¹FR321 / ²FR331

WEIGHT

Approximate mass 450 kg ¹ / 495 kg ²

ELECTRICITY

Rated voltage (tolerance ± 5%) 3x400 Vac 3LNPE
 Rated current 32 A
 Assigned frequency 50 Hz
 Maximum power 18 kW
 Average consumption (approx.) 10 kWh
 Building residual current circuit breaker FI (DDR) 30 mA, type B, HI
 Upstream overload cut-off 40 A/C

TEMPERATURE CONTROL

Max temperature up to 220°C
 Temperature rise time 10 - 20 minutes
 Heating zones 3 zones with independent settings

OPERATIONAL FEATURES

Number of operators Supervisor only
 Noise level 72 dbA ± 0.1

DIMENSIONS

Measures in mm

¹FR321 / ²FR331

⊛ = +/- Height adjustment (230mm)

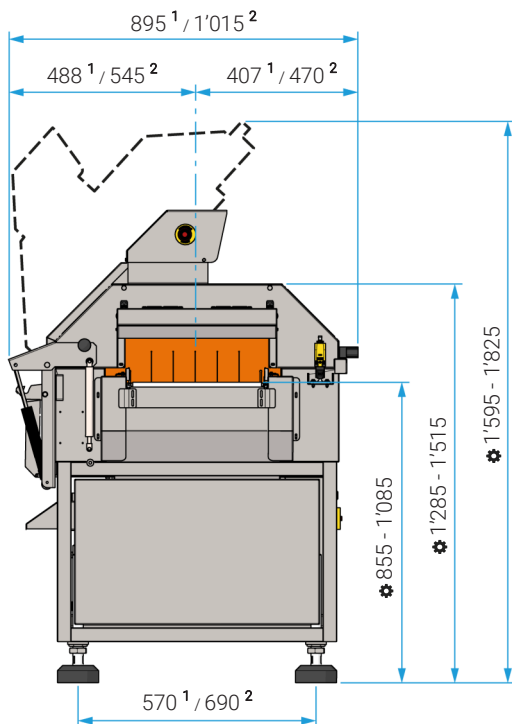

CONVEYOR

Operating speed

60 products / min

Standard speeds and options: see table below

Frequency ↓	Conveyor speed (m/min)		
	Standard	Fast conveyor upgrade kit	Very fast conveyor upgrade kit
20 Hz	7	10	17
50 Hz	18	25	43
80 Hz	28	40	68

PASSAGE UNDER VAULTS

Variations of +/- 5mm possible

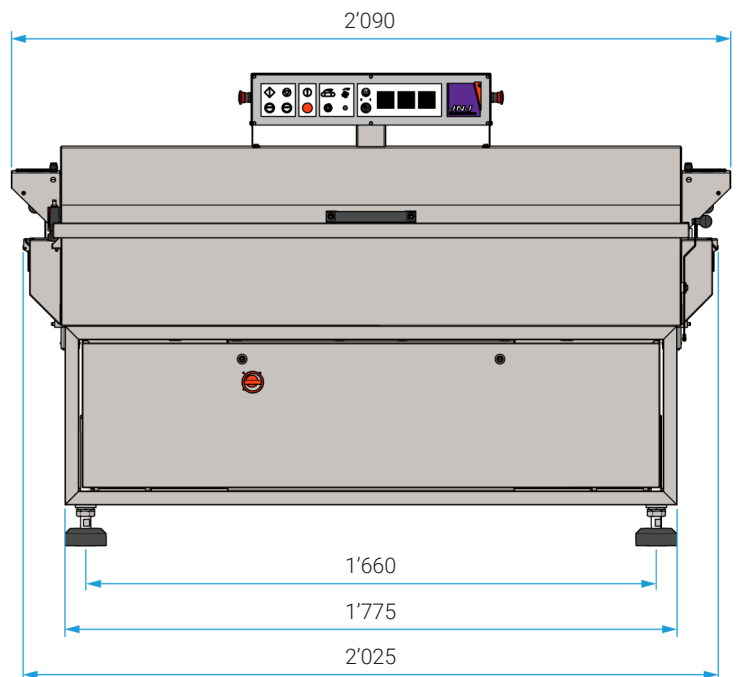
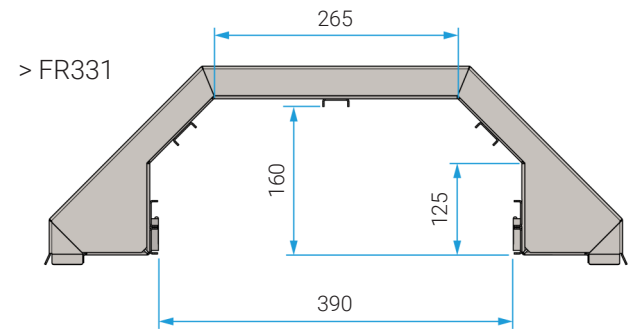
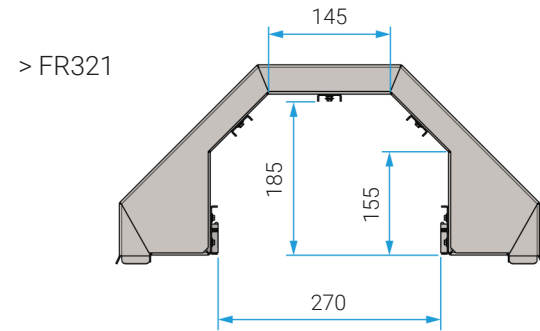

© JNJ automation SA. All rights reserved. The products and specifications shown in this document are subject to change at any time and without notice. Updated: 18/10/2021



JNJ automation SA

Impasse de la Maladaire 5 | CH-1680 Romont | Tél +41 26 656 9000 | info@jnj.swiss | www.jnj.swiss

Article #012424 (321)

#026716 (331)