



TR05

CHEESE SLICING MACHINE

IDEAL FOR HARD AND SEMI-HARD CHEESES



PRESENTATION

The TR05 is the ideal solution for cutting portions.

Designed with cheese factories and dairy stores in mind, this compact unit will be easy to find room for in your store for direct sales or in your preparation workshop.

The unit's many accessories make safe, precise cuts to create segments, strips, cubes, sticks, thin slices, etc.



DESIGN

Less stress on workers' joints; reduces harshness of working conditions.

Attractive, sober design on customer-facing side.

Compact design, suitable for tables and counters.

Performance and ergonomics.

Quicker in-store service and order preparation.

Delivers clean, precise product cuts.



CONSTRUCTION

Tool-free removal of components.

Revolutionary press system allows soft cheeses and thin slices to be cut without crushing the cheese. Prevents cheese from rising without applying undue pressure.

Electric motor drive blade.

Wide range of accessories.

Easy to clean.

Made from food-grade plastic and stainless steel.

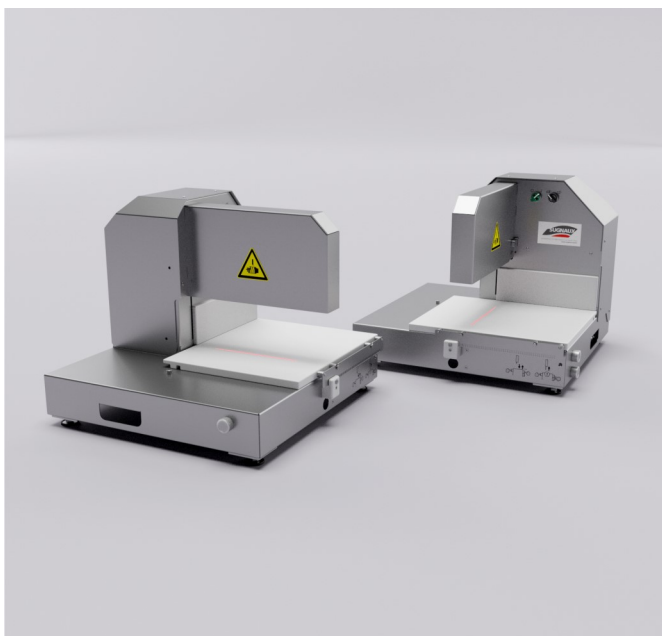

PRECISION AND SAFETY

Laser indicator shows cutting position.

Two-hand safety control.

Stops immediately when one button is released.

Lifting function.

Blade is shielded when raised.

Accessories can be handled without touching the blade.

STANDARD EQUIPMENT

1. Fixed rectangular table

Tray surface 610 x 370 mm

Use:

> Standard tray, maximum surface area, easy to clean

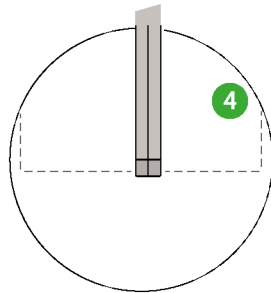
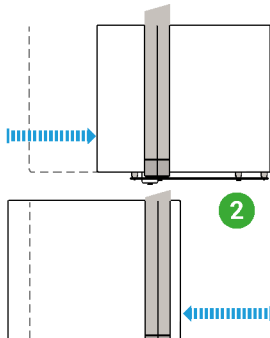
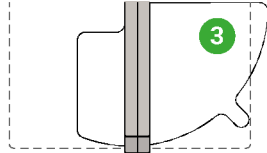
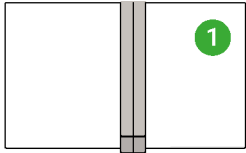

5. Cutting support for 2 parts of "Têtes-de-Moine"

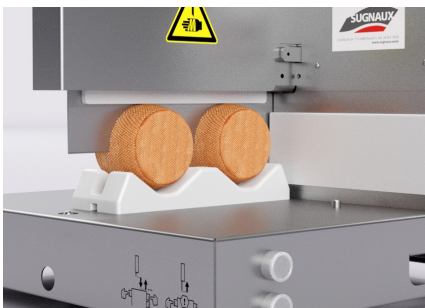

OPTIONS

2. Graduated mobile table

Tray surface 440 x 375 mm

Tray travel (max.) 280 mm

Graduations 7, 8, 10, 15, 20 mm
or customised measure on request

Examples of use:

- > Cutting strips and cubes
- > Cutting sticks for cheeseboards
- > Cutting slices for raclette

3. Swivel table, quarter cheese wheel

Tray radius (max.) 330 mm

Rotation angle (max.) 90°

Option: tray graduation 1/64°

Examples of use:

- > Preparing triangles quickly and easily
- > In-store cuts 'on demand'

4. Circular rotating table

Tray diameter 660mm

Tray graduation 1/16°

Examples of use:

- > Cutting cheeses up to 660 mm diameter
- > Cutting 1/4 cheese wheels for shops
- > Cutting triangles
- > Leave an assortment of cheeses on the tray, ready to cut

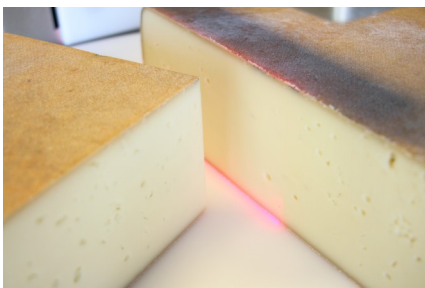

TECHNICAL INFORMATION

The values shown are for information only.
They may be adapted to the specific needs of each customer.

WEIGHT

Weight (approx.) 82 kg

ELECTRICITY

Rated voltage (tolerance $\pm 5\%$) 1x230VAC Vac 3LNPE
 Rated current 10 A
 Assigned frequency 50 Hz
 Maximum power 0.4 kW
 Average consumption (approx.) 0.1 kWh
 Building: residual current circuit breaker FI (DDR) 30 mA, type B, HI
 Building: Upstream overload cut-off 16 A/C

VERSIONS OF THE MACHINE

Standard frame or compact frame (⚙️1)
 Cut height: 130 or 160mm (⚙️2)

WORKING SPECIFICATIONS

Blade length (= Cut width) 345 mm

(⚙️2) Cut height (for each machine version)
 > TR05 - Low version 130 mm
 > TR05 - High version 160 mm

NOTE: Specify your chosen option on your order. Height can be altered after delivery, but only by the manufacturer.

Cutting area indication by laser
 Machine operation by bi-manual controls
 Functions Speed 1 cut
 Speed 2 cut
 Blade lift

DIMENSIONS OF THE MACHINE

Measures in mm

COMPACT VERSION (⚙️1)

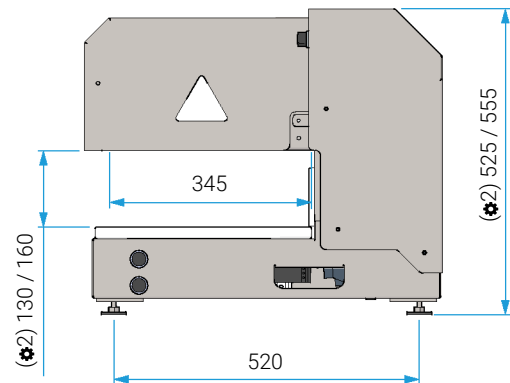
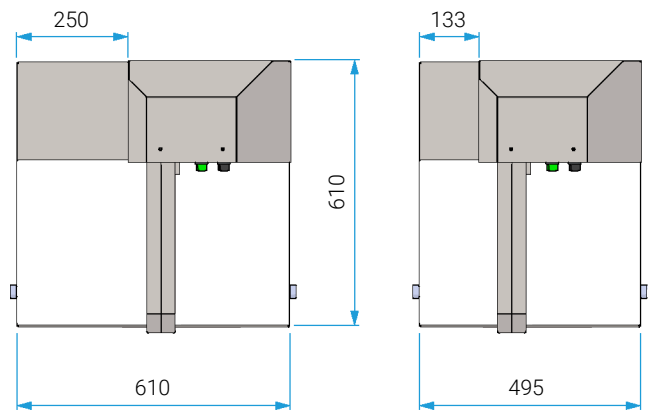
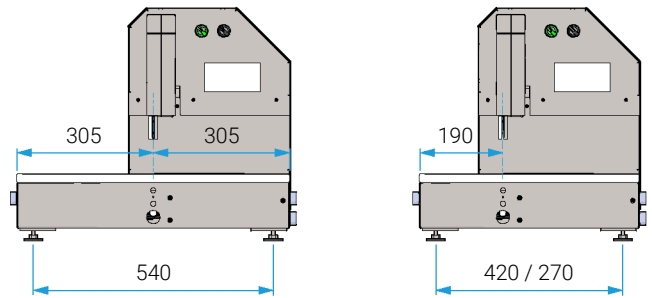

DIMENSIONS INCL. OPTIONAL EQUIPMENT

Measures in mm

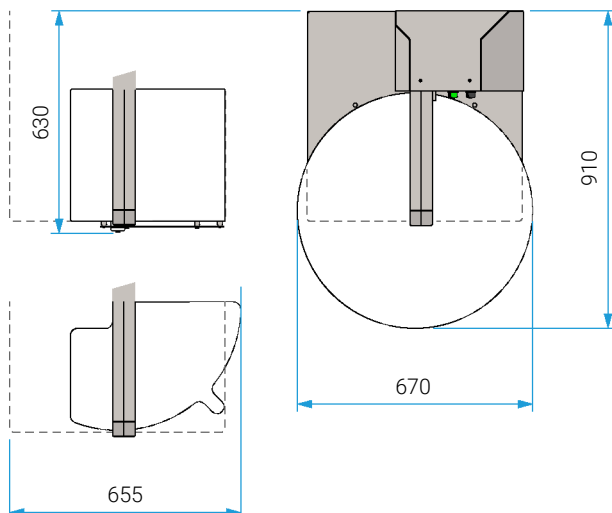

TR05 WITH ITS ACCESSORIES

