



# CHP

## CHARIOT À PLANCHES

DÉPLACER ET STOCKER FACILEMENT VOS PLANCHES



## PRÉSENTATION

Sécher, déplacer et stocker vos planches en une opération avec les chariots CHP.

Grâce à nos quatre configurations, vous avez la possibilité de choisir la version la plus adaptée à votre infrastructure. Construits en inox, les châssis robustes et faciles à nettoyer surmontent des roues en matière plastique hygiénique de grand diamètre.

# CHP1

Article #013914

80 PLANCHES

Masse à vide :

80 kg

Planche : (larg. x ep.)

(max.) 300 x 35



Dimensions en mm

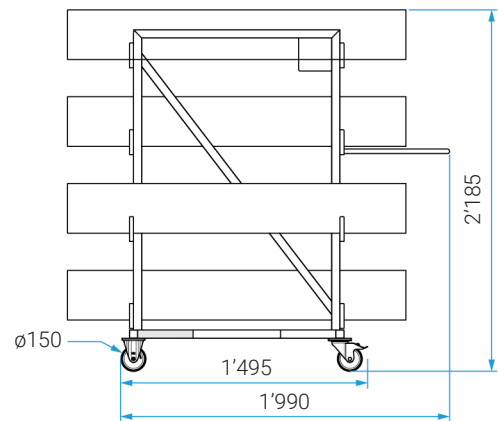
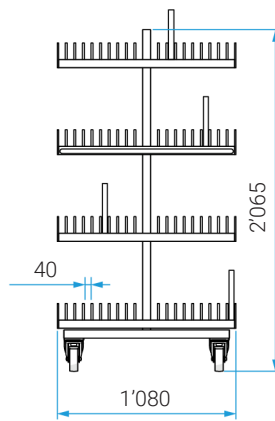

# CHP2

Article #029972 <sup>1</sup>

Article #030894 <sup>2</sup>

72 PLANCHES

Masse à vide :

110 kg

Planche : (larg. x ep. x long.)

(max.) 300 x 35 x 2'050

Variante avec roue :

ø150 <sup>1</sup> / ø100 <sup>2</sup>

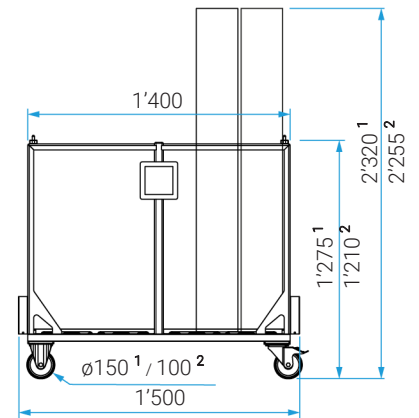
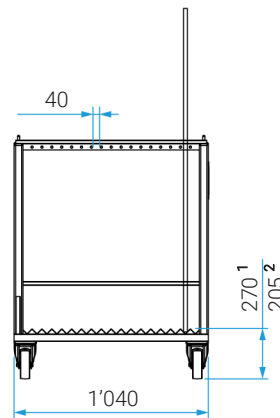

# CHP3

Article #013913

72 PLANCHES

Masse à vide :

80 kg

Planche : (larg. x ep.)

(max.) 320 x 35

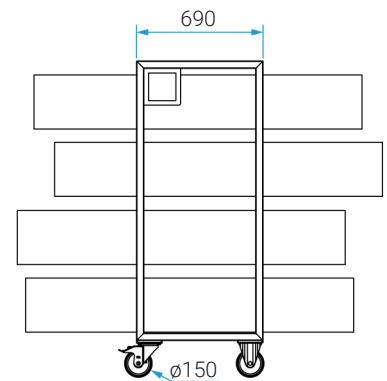
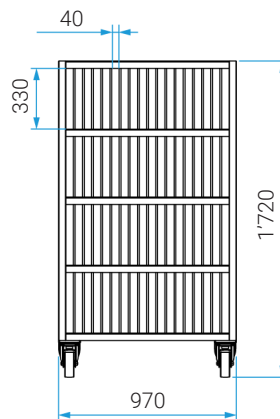

# CHP4

Article #049547

100 PLANCHES

Masse à vide :

80 kg

Planche : (larg. x ep.)

(min.) 220 x (max.) 25

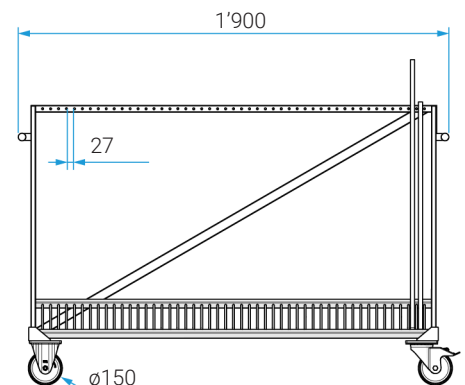
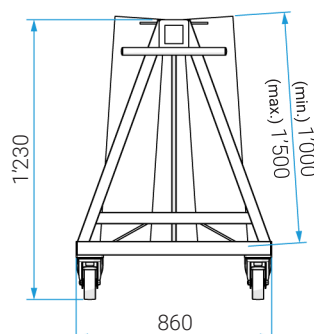
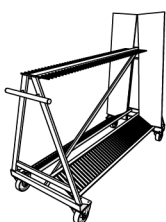

JNJ automation SA

Impasse de la Maladaire 5 | CH-1680 Romont | Tél +41 26 656 9000 | info@jnj.swiss | www.jnj.swiss